Direct Current Motors¹

Direct current motors have some unique characteristics that are not easily achieved with alternating current motors. These motors have windings on the armature or moving part of the motor and it is necessary to make an electrical connection from the stationary part of the motor to the rotating armature. The electrical connection is achieved with what is called the commutator and brushes. The commutator is a moving set of metal conducting pads and the brushes must slide across the commutator as it is rotating. This Tech Note will discuss how a direct current motor operates as well as the different types of direct current motors and their characteristics.

How a Direct Current Motor Works: If a conductor is placed in a magnetic flux and a current is made to flow in the conductor, the conductor will move. The left hand rule for motor action explains the direction the wire will move. The key here is that the current in the conductor is from an independent source and is not induced. Point the index finger of the left hand in the direction of the flux from North to South, and point the second finger of the left hand in the direction the current is flowing in the conductor. The thumb of the left hand will point in the direction the wire will move. Another way to determine the direction of motion of a wire suspended in a magnetic flux with a current flow in the wire is to examine the orientation of the flux created by the current in the wire with respect to the external magnetic flux. Note in Figure 318.1 that on the left side of the wire the flux is oriented in the same direction and on the right side of the wire the flux is oriented in opposite directions. The flux will be strengthened on one side and weakened on the other resulting in a movement of the wire in the direction of the weakened magnetic flux. Reversing the direction of current flow in the wire suspended in the magnetic flux will result in the wire moving in the opposite direction.

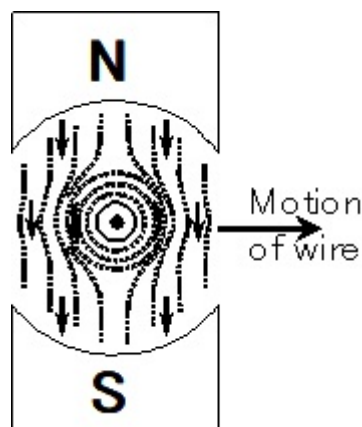

Figure 318.1 If current is placed in a wire suspended in a magnetic flux, the wire will move. Magnetic flux will strengthen on one side of the wire and weaken on the other side of the wire.

¹Developed by Truman C. Surbrook, Ph.D., P.E., Master Electrician and Professor, and Jonathan R. Althouse, Master Electrician and Instructor, Biosystems & Agricultural Engineering Department, Michigan State University, East Lansing, MI 48824-1323. For a copy of this Tech Note and other educational papers, visit the [Electrical Technology](http://www.egr.msu.edu/age/) web site at <http://www.egr.msu.edu/age/>
MSU is an affirmative-action, equal-opportunity employer.

When a loop of wire is mounted on a shaft so that it is free to turn about a central axis, current flow through the wire loop will cause the loop to rotate if it is suspended in an independent magnetic flux as illustrated in Figure 318.2. A direct current is passed through the wire loop by means of brushes and a commutator. The force exerted on each half of the loop will result in a turning motion. If the direction of current flow through the loop or if the poles of the external magnet are reversed, the direction of rotation of the loop will be reversed.

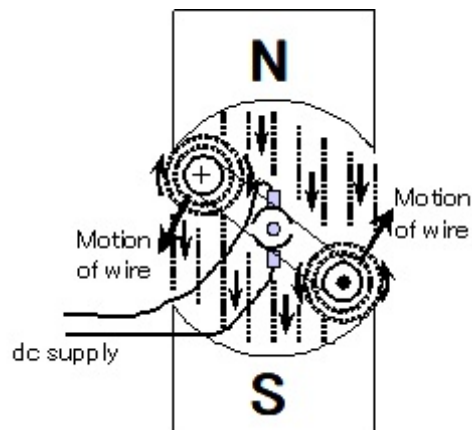

Figure 318.2 When direct current is passed through a loop of wire suspended in a magnetic flux, the loop will rotate with the direction of rotation determined by the orientation of the magnetic flux and the direction of current flow through the wire loop.

Construction of a DC motor: A direct current motor consists of a magnetic field in the stator that is fixed in place and not moving. Windings are placed on the rotor (called an armature). Current is delivered to the rotating armature through a commutator and brushes on one end of the shaft. A specific circuit is created in the armature that is positioned to repel the external magnetic field. The operating speed of the rotor is a balance between the load, the strength of the field flux, and the speed of the rotor. Current flow in the armature winding creates a magnetic flux that is rotating inside the motor. The magnetic flux of the stator is stationary. When the moving armature flux passes the stationary winding in the stator, a voltage is induced in the stator winding that opposes the supply voltage forcing current through the stator winding. The rotor will speed up until the induced reverse voltage ($E_{INDUCED}$) is equal to the supply voltage (E_{SUPPLY}) minus the winding voltage drop, Equation 318.1. The winding voltage drop is equal to the current (I) times the winding resistance (R). Understanding this relationship is necessary to understanding armature speed.

$$E_{INDUCED} = E_{SUPPLY} - (I \times R) \quad \text{Equation 318.1}$$

Rotor speed of a dc motor will increase until the previous equation is satisfied. If the field weakens, the rotor must speed up to produce the needed induced voltage in the winding. If the load increases, the $I \times R$ drop will increase and less induced voltage is needed, therefore, the rotor will slow down.

Types of Direct Current Motors: There are four basic types of direct current motors; series, shunt, compound, and permanent magnet. The compound is a combination of series and shunt. The field is produced in the outer frame of the motor or stator. Power is produced by current flow through the windings on the armature. There are multiple circuits in the armature. A simplified armature is shown in Figure 318.3. Direct current flows through only one armature circuit at a

time. The flow of current through the armature winding creates a North and South pole in the armature in just the right position that it will be repelled by one field pole and attracted to the other field pole. As the armature winding gets to the horizontal position between the field poles, the direction of armature current flow must be changed in order to keep the armature moving in the same direction. Notice the change in plane in Figure 318.3.

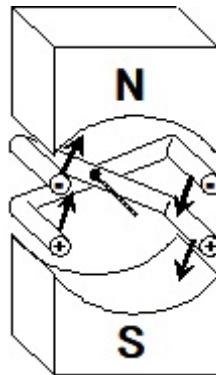
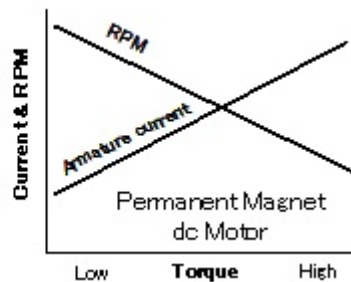
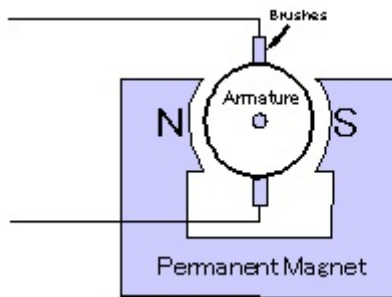

Figure 318.3 A commutator and brushes are used to reverse the direction of direct current flowing in the armature winding to keep the armature turning in the same direction.

Permanent Magnet DC Motor: A permanent magnet dc motor has a permanent magnet and no windings in the stator as shown in Figure 318.4. The strength of this magnetic field is constant and unaffected by current flow through the armature winding. This type of motor is designed for a fixed speed at full load. If the motor is allowed to run free with no load, the motor will speed up until the induced voltage in the armature winding satisfies Equation 318.1. In this case the induced voltage will be lower than the supply voltage.

This type of fixed maximum Motor current are plotted in Figure 318.4.



only slightly supply voltage. motor will have a armature speed. and shaft rpm against torque in

Figure 318.4 The stator magnetic field can be created using a permanent magnet. This type of direct current motor has a fixed maximum speed and can easily have the shaft rotation reversed by reversing the polarity of current applied to the motor.

Because the field has a fixed flux, the motor current and rpm will be linear with respect to torque. As the torque requirement increases, the motor will slow down and current will increase.

These motors can be designed to operate at a fixed speed similar to an induction motor. Speed can be varied by limiting the voltage to the armature. The current must increase when the torque requirement increases. By reducing the current to the armature, the shaft rpm can be reduced. Direction of rotation of the armature can be changed by simply reversing the polarity of the direct current supply to the armature. This can be done anywhere in the circuit. With other dc motors with a field winding, direction of shaft rotation is changed by reversing the dc polarity to the armature with respect to the polarity of the supply to the field.

Shunt Field DC Motor: A separate winding is placed in the stator to produce the field. This field is connected in parallel with the armature. The current through the field is quite small while the current through the armature will be large and is dependant upon the torque requirement. A shunt field dc motor is shown in Figure 318.5. The magnetic field strength of the field is independent of the current through the armature, which is due to the load. Shaft speed has a fixed upper limit as shown in the following graph. Because the field strength is constant, the shaft rpm and motor amps will change linearly with an increase in the torque requirement.

Shunt field dc motor shaft speed is most easily controlled by varying the strength of the field flux. Lowering the current through the field winding will decrease the field flux. Referring to Equation 318.1, the rotor must increase in speed to produce the necessary induced winding reverse voltage. The speed is reduced by increasing the current through the field winding. Complete loss of the dc supply to the field will result in a significant increase in armature speed if there is little or no load on the motor. This is called a runaway armature condition which can result in damage to the motor. Motor shaft speed can be controlled by varying the voltage to either the field or the armature. Typically the shaft speed is controlled by varying the current to

the field is a much to control.

This suited for where a constant required setting. speed is constant

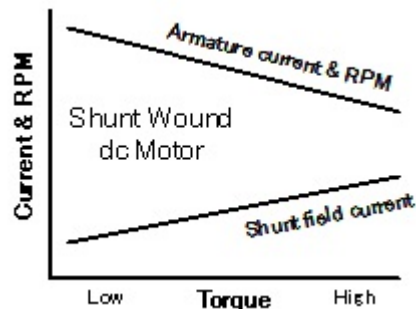
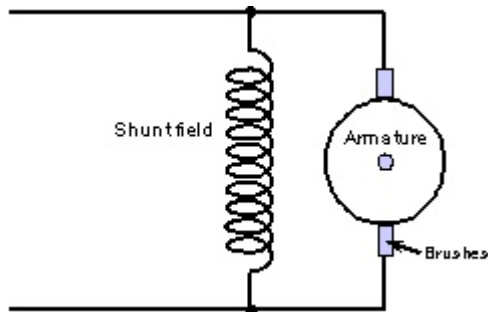

because this lower current

motor is well applications relatively speed is at each speed The shaft relatively with changes

in load. This type of dc motor would be reasonably suited to a materials metering auger that is to be set at different metering rates. A predictable shaft rotation at each speed setting can be obtained even if there is some variation in load. A disadvantage of this type of motor is that it has low starting torque. A change in armature rotation direction is obtained by reversing the leads of the armature with respect to the leads of the field.

Figure 318.5 A shunt wound dc motor has the stator field connected in parallel with the armature winding. This type of dc motor has a relatively constant speed with varying load.

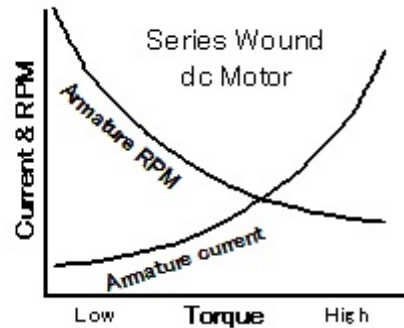
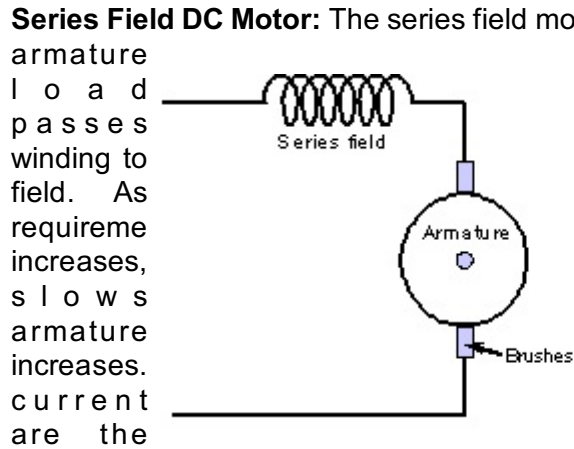

Motor current also through the field produce the torque of the load the armature current and field current same current,

therefore, field flux strength increases as load increases. The result is that very high torque can be obtained at low shaft rpm. A series field dc motor is shown in Figure 318.6. Armature rpm will drop rapidly with an increase in load torque as shown in Figure 318.6. Note that as the load torque gets very small, the armature rpm increases rapidly with no theoretical limit. These motors should be used in applications where the load cannot be lost accidentally such as a broken belt. Steps must be taken to prevent a runaway armature with loss of load. It is best to directly couple the motor to the load.

Series field motors are often called *universal* motors because they can be operated from an ac or a dc power supply. Even though the field polarity is constantly changing with an ac power source, so does the armature field polarity, therefore, the same forces will occur with an ac or a dc power supply. Universal motors are used for many ac power applications such as an electric drill. Generally higher horsepower can be obtained from series field dc motors for a given frame size than for other types of ac or dc motors. These motors are not well suited for applications where relatively constant shaft speed is needed with a varying load. A change in armature rotation direction is obtained by reversing the leads of the armature with respect to the leads of the field. Shaft speed can be controlled by controlling the current drawn by the motor.

Figure 318.6 A series wound direct current motor has the stator field connected in series with the armature winding. This type of dc motor has a widely varying speed with changing load.

Compound Field DC Motor: This motor has one field winding that is in series with the armature and one that is in parallel. A compound wound motor is shown in Figure 318.7. This motor tries to capture the best characteristics of the series and shunt field dc motors. This motor has higher starting torque (low rpm torque) than the shunt motor, but does not have as high a low rpm torque as the series dc motor. The shaft speed remains relatively constant as the load varies, but not as

constant a speed as the shunt dc motor. Also shown is a graph of the motor current and shaft rpm variation verses torque. Speed can be regulated by changing the voltage to the field or to the armature. The current through the armature winding is dependant upon the load, and is a higher current to control than the field current. Just like the series and shunt motors, shaft rotation direction is changed by reversing the field winding leads with respect to the armature leads.

Figure 318.7 A compound wound dc motor has a stator field connected in series with the armature winding and another connected in parallel with the armature winding. This type of direct current motor has a relatively constant speed with varying load and high starting torque at low rpm.

Conclusion: Direct current motors have an advantage over ac induction motors with respect to low cost light weight speed control. Inexpensive compact circuits using solid state thyristors can act as current limiters for speed control. Direct current motors are used for applications where very high shaft rpm is necessary. The series wound dc motor has the added advantage of being capable of being operated from an ac or a dc supply, although generally higher torque is obtained when operated from a dc supply. Since the advent of rechargeable compact batteries with high power storage, direct current motors have become commonplace for use in portable power tools.

