

## Three-Phase Electrical Systems

Electrical power is commercially produced with a generator that has three windings each producing electrical current that is  $120^\circ$  out of phase with the other phases as shown in *Figure 220.1*. Voltage is changed using transformers that have a set of windings for each phase. This can be done with one transformer with three windings or using three individual transformers. There are two ways these transformer windings can be connected depending upon the requirements of the load to be served. This *Tech Note* discusses the different types of 3-phase electrical systems and their applications. Single-phase power can be obtained by connecting to any two of the wires of a 3-phase electrical system.

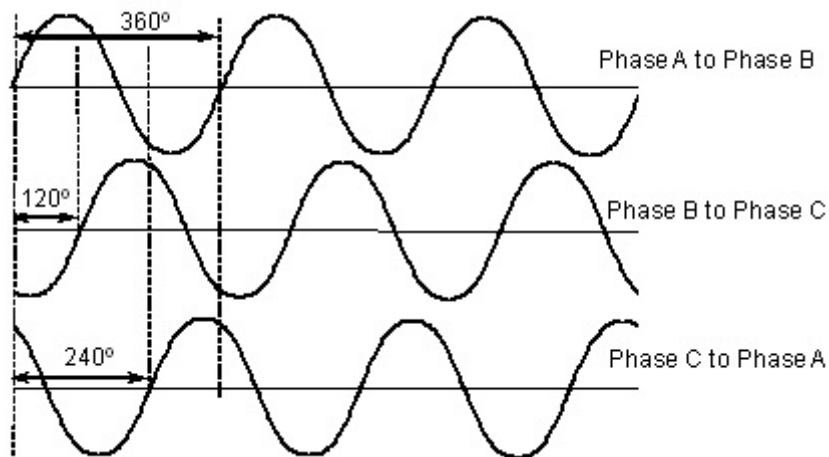

**Figure 220.1** There are three ungrounded wires for a 3-phase electrical system and the voltage between each set of wires will be a sine wave, each off-set by  $120^\circ$ .

**Connecting 3- Phase Transformer Windings:** There are only two ways the windings of a 3-phase transformer can be connected. They can be connected in a loop as shown for the primary side of the transformer of *Figure 220.2*. Making a diagram of this type of connection results in an equilateral triangle that looks like the Greek letter *delta*. This is called a *delta* connection. The other way to connect a set of 3-phase windings is to connect one side of each winding together with the other pointing out like the spokes of a wheel. A diagram of this connection looks like a three-pointed star or if arranged correctly it will look like the letter **Y**. This type of connection is named for the letter **Y**, but it is spelled **wye**. Whether a 3-phase transformer has the windings connected wye or delta will depend upon the type of electrical system needed and the voltage requirements of the loads to be supplied. When the transformer windings are connected wye, there is usually a common wire (neutral) connected to the common winding point giving a 4-wire 3-phase system. In the following diagrams of 3-phase electrical systems, only the secondary winding of the transformer will be shown. There is a primary winding for each secondary winding and it is not required to be connected in the same manner as the secondary winding.

For most applications, a special 3-phase electrical panel is required which will have a 3-pole main circuit breaker and three bus bars — one for each phase. Typically the phases are named A, B, and C. The electrical code requires the lettering to be from the left conductor in the panel to the right conductor. It is a good idea to mark the service and feeder phase conductors with colored tape or label them with letters. When working on a 3-phase electrical system, care must be taken not to reverse any phase conductor or motor rotation will be reversed.

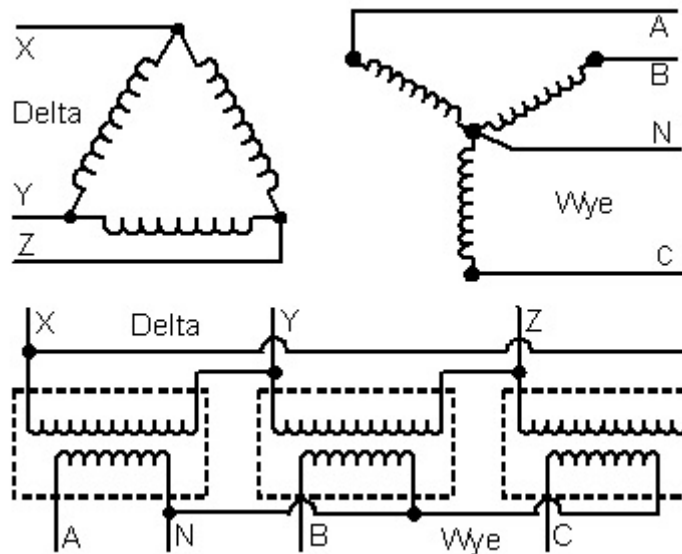

**Figure 220.2** Three individual transformers are used to change the voltage of a 3-phase electrical system with the windings in this case connected in a delta on the primary side and a wye on the secondary side.

Loads such electric motors of equal horsepower rating draw less current when operating from a 3-phase supply than a single-phase motor operating at the same voltage. The 3-phase motor will have three supply conductors while the single-phase motor will have two supply conductors. Single-phase motor current will be approximately equal to 3-phase motor current times **1.73**. Power in a single-phase circuit is equal to the voltage times the current times the power factor. Refer to *Equation 220.1*. In a 3-phase circuit power is equal to **1.73** times the voltage times the current times the power factor as shown in *Equation 220.2*.

**Single-Phase**

$$\text{Power} = \text{Volts} \times \text{Amps} \times \text{power factor} = E \times I \times \text{pf} \tag{Eq. 220.1}$$

**3-Phase**

$$\text{Power} = 1.73 \times \text{Volts} \times \text{Amps} \times \text{power factor} = 1.73 \times E \times I \times \text{pf} \tag{Eq. 220.2}$$

**Three-Phase 208/120 Volt, 4-Wire Wye:** A 3-phase, 4-wire wye electrical system is ideal for supplying buildings that have many circuits operating line to neutral such as lighting and general-purpose receptacle outlets. With this type of system, there are three ungrounded conductors and the neutral or common conductor originating at the point where the three transformer secondary windings are connected. A 3-phase, 4-wire, 208/120 volt electrical

system is illustrated in *Figure 220.3*. In the case of a wye electrical system, the voltage between any two phase conductors is **1.73** times the voltage from phase-to-neutral. The voltage in one transformer winding is 120° out of phase with the voltage in any adjacent winding. As a result, the voltage across each winding cannot be added arithmetically. To find the phase-to-phase voltage of a wye electrical system given the phase-to-neutral voltage, multiply the phase-to-neutral voltage by **1.73** as shown in Equation 220.3. To find the phase-to-neutral voltage of a wye electrical system given the phase-to-phase voltage, divide the phase-to-phase voltage by **1.73** as shown in *Equation 220.4*.

**Wye electrical systems only**

$$\text{Phase-to-phase voltage} = 1.73 \times \text{Phase-to-neutral voltage} \tag{Eq. 220.3}$$

$$\text{Phase-to-neutral voltage} = \frac{\text{Phase-to-phase voltage}}{1.73} \tag{Eq. 220.4}$$

If the major load in a building is electric motors and electric discharge lighting, then the most practical 3-phase, 4-wire electrical system to use is a 480/277 volt wye system. The phase-to-phase voltage is 480 volts and by dividing this by **1.73** the phase-to-neutral voltage will be 277 volts. Electric discharge lighting ballasts are commonly available to operate at 277 volts. The electrical system will look exactly the same as shown in *Figure 220.3* except the 120 volts is replaced with 277 volts and the 208 volts is replaced with 480 volts. The panel and circuit breakers must be rated for this higher set of voltages.

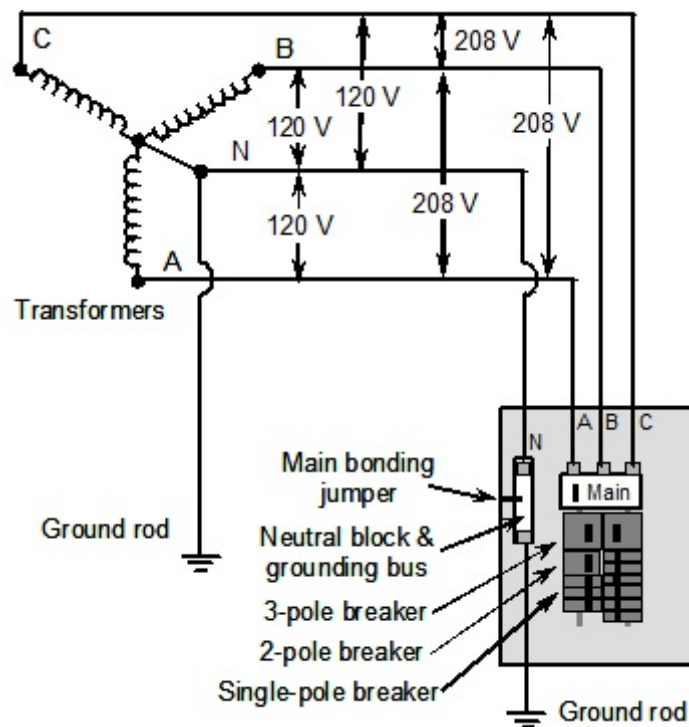

**Figure 220.3** A 208/120 volt, 4-wire, 3-phase wye electrical system, common for commercial buildings, provides single-phase power at 120 and 208 volts and 3-phase power at 208 volts. The wye electrical system can also operate at 480/277 volts.

**Three-Phase, 240 Volt or 480 volt, 3-Wire Ungrounded Delta:** In cases where the only load to be supplied is electric motors or similar 3-phase loads, a delta 3-wire electrical system is satisfactory because a neutral conductor is not needed. The electrical code permits such a system to operate without a direct connection to ground. The 3-phase delta 3-wire system can supply power at 240 volts or it can supply power at 480 volts depending upon the need. *Figure 220.4* illustrates a 480 volt, 3-wire, ungrounded delta 3-phase electrical system. Note at the transformer there is no connection to ground. At the service panel the electrician is required to install a ground which is only connected to the service panel enclosure. Supplying a load with this type of electrical system involves installing a 3-pole circuit breaker and running three phase conductors. An equipment grounding conductor must also be run for safety. If a 120 volt circuit is needed for lights and receptacles, then an additional single-phase transformer will need to be installed to step the 240 or 480 volts down to 120 volts.

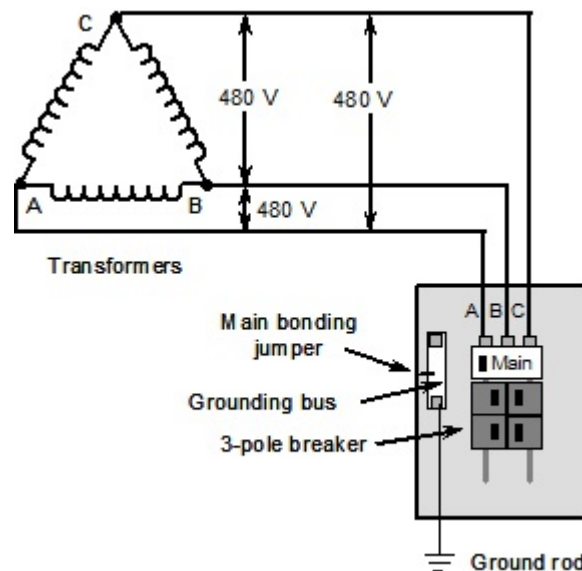

**Figure 220.4** A 3-phase, 3-wire, ungrounded delta electrical system operating at 480 volts (sometimes 240 volts) is suitable for applications where most of the load to be served is electric motor load and similar 3-phase loads such as electric heaters.

**Three-Phase, 240 Volt, 3-Wire Corner Grounded Delta:** The 3-phase, 3-wire, delta corner grounded electrical system is used generally for the same applications as the ungrounded delta system except the transformer windings are grounded. This system can operate either at 480 volts or at 240 volts. *Figure 220.5* shows a corner grounded, 3-wire, 3-phase system operating at 240 volts between phase conductors. The utility grounds one of the phase conductors at the transformer. This is called the grounded phase conductor by the electrical code and is required to have a white marking. This is a phase conductor, not a neutral. It usually terminates at a grounding bus in the main service panel, and the electrician is required to ground this conductor to the earth at the service panel. Only two of the phase conductors are required to have overcurrent protection. The grounded phase conductor is not permitted to have overcurrent protection unless it is a circuit breaker that also opens the other phase conductors. A load such as an electric motor is wired the same as other motor circuits except one phase conductor will originate at the grounded phase terminal of the service panel and the other two phase conductors will originate at a circuit breaker. In addition to the three phase conductors, an equipment grounding conductor is also required. The grounded phase conductor is not permitted to serve as the equipment grounding conductor.

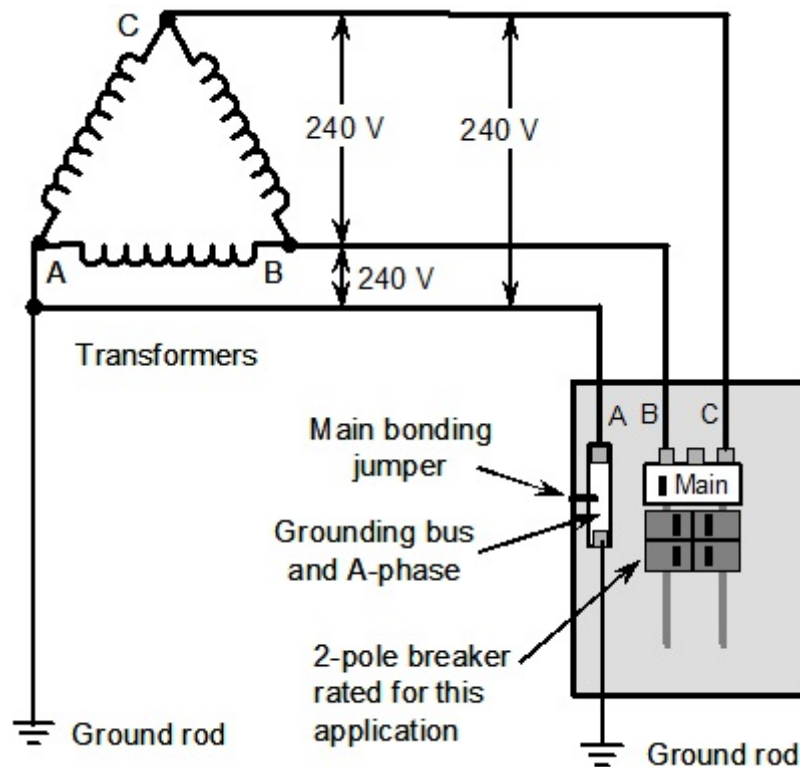

**Figure 220.5** A 3-phase, 3-wire, delta electrical system is permitted to have one phase grounded. The grounded phase conductor is not permitted to have overcurrent protection. It is required to be grounded at the transformer by the utility and at the service panel by the electrician. This system operates at 240 volts between phase conductors. The system is also permitted to operate at 480 volts between conductors.

**Three-Phase, 240/120 Volt, 4-Wire Center-Tap Grounded Delta:** There are some applications where 3-phase power at 240 volts is desired, and also single-phase power at 120 volts and at 240 volts. All three requirements can be met by one set to transformers connected in a delta with a center-tap to one of the transformers as shown in *Figure 220.6*. This type of electrical system is used for many farm and small commercial applications. When a load such as an electric motor is supplied, a 3-pole circuit breaker is installed in the service panel. Single-phase 240 volt loads can be supplied using a 2-pole circuit breaker, although the circuit breaker must be rated for this type of application. Single-phase 120 volt loads can be supplied using a single-pole circuit breaker — but there is a caution. With this system there will be 120 volts from the neutral to two phase conductors, and 208 volts from the neutral to the other phase conductor. The electrical code calls that phase conductor the phase with the higher voltage to ground. Electricians generally call that phase the high leg or the wild leg. *Do not install any single-pole circuit breakers in the panel connected to the high leg.* The electrical code requires the high leg to be the center phase (**B phase**) and be marked with **orange tape** or paint everywhere it is visible. This is a very versatile system, but caution must be taken to prevent misuse of the high leg. Reference to the required marking of the *high leg* of a 3-phase, 4-wire, 240/120 volt electrical system is found in **Section 110.15** of the *National Electrical Code*.

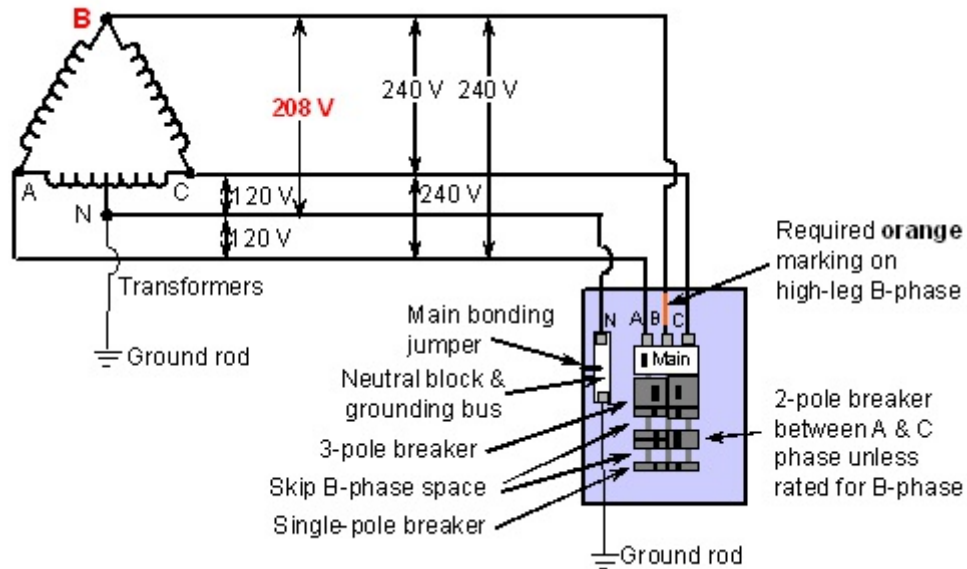

**Figure 220.6** A 240/120 volt, 4-wire, 3-phase delta electrical system provides single-phase power at 120/240 volts and 3-phase power at 240 volts. One phase has a higher voltage to ground and that phase must be identified with an orange marking.

**Open Delta 3-Phase Electrical Systems:** All of the delta 3-phase electrical systems previously described can be operated with one of the primary phase conductors missing. One example of this type of electrical system is shown in *Figure 220.7*. Note that the electrical system in *Figure 220.7* looks exactly like the one in *Figure 220.6* except one of the transformers has been removed. One advantage of this type of system is that the utility is able to provide 3-phase power to a customer even when one of the phase conductors of the primary distribution system is not available.

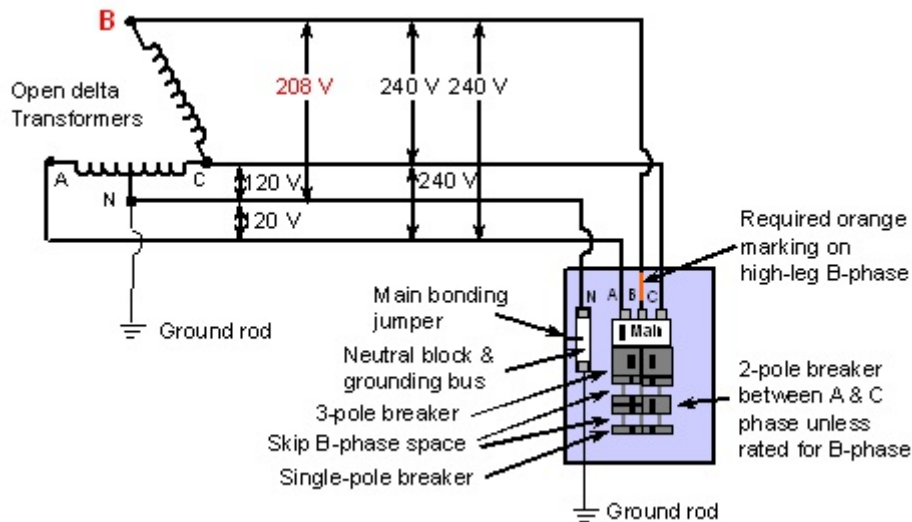

**Figure 220.7** The utility can provide 3-phase power to a customer with an open delta system when one of the distribution system phase conductors is not available. This system is the same as in *Figure 220.6* except one transformer has been removed.



Utility electrical distribution of primary power in many parts of the country is done with what is known as a multi-grounded wye electrical distribution system. The three windings of the utility substation distribution transformers are connected in a wye configuration with the common point of the wye connected to the earth by means of an extensive grounding electrode at the substation. The distribution wires supplying power to customers are three ungrounded (hot) phase conductors on insulators and a neutral wire generally not mounted on insulators. There is a grounding electrode such as a ground rod connected to this primary neutral wire at every customer transformer location and often at poles between customer locations. When a customer is supplied single-phase power, the primary winding of the transformer is connected to one of the primary phase conductors and to the neutral conductor. Refer to *Tech Note 219* for a description of a single-phase connection. For a 3-phase connection to a multi-grounded distribution line three individual single-phase transformers are generally used with each transformer primary connected to one of the primary phase wires and the other terminal of each transformer connected together and to the primary neutral as well as to a grounding electrode. This is illustrated in *Figure 220.8*. When a 3-phase delta electrical system is supplied from a 3-phase wye distribution line it is possible to provide the customer 3-phase electrical power as shown in *Figure 220.7* with one of the transformers removed. Two transformers are used rather than three transformers as shown in *Figure 220.7* and *Figure 220.9*. This is called an open delta connection. More about utility electrical distribution can be found in *Tech Note 225*. The delta systems shown in *Figure 220.4* and *Figure 220.5* can also be operated open with one transformer removed.

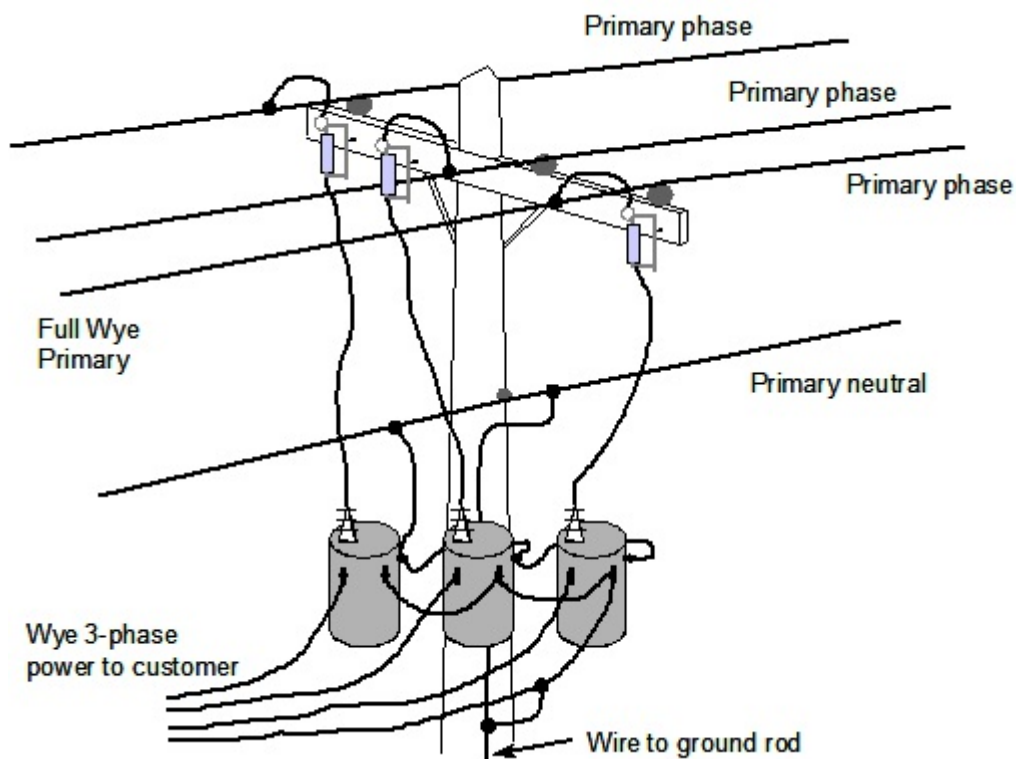

**Figure 220.8** The utility primary distribution line has three phase conductors and a grounded neutral wire. Note that one primary terminal of each transformer is connected to a different phase conductor and the other primary terminals of each transformer are connected together, connected to the primary neutral wire, and also connected to a grounding electrode.

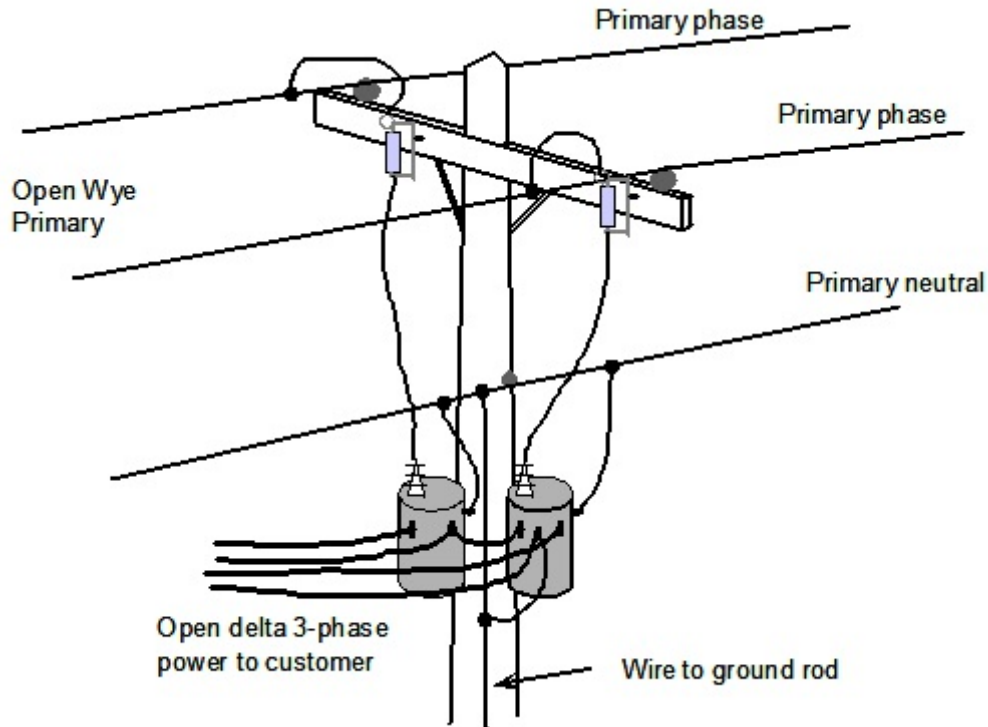

**Figure 220.9** The utility primary distribution line has only two phase conductors and a grounded neutral wire. One primary terminal of each transformer is connected to a primary phase conductor and the other primary terminal of the two transformers is connected together and connected to the primary neutral as well as to a grounding electrode. This is called an open delta connection.

**Conclusions:** Utility electrical power is generated and distributed as 3-phase, 60-Hz, alternating current where both single-phase power and 3-phase power can be provided. The transformers that change the voltage at various points along the system can be connected in only two configurations, as a delta or as a wye. Depending upon the requirements of the customers, the utility can provide electrical power as single-phase or as 3-phase in a variety of standard nominal voltages. Single-phase power can be provided as 120 volts, but most single-phase power is provided with a center-tapped transformer that provided both 120 volts and 240 volts. The wye 3-phase transformer configuration generally provides power at 208 volts between phases and 120 volts from phase-to-neutral, or different transformers can be used that provide power at 480 volts between phases and 277 volts from phase-to-neutral. If only 3-phase power is needed it can be provided with a delta configuration at either 240 volts or at 480 volts. A different set of transformers is needed for each of these voltages. Because this is a delta configuration the system can be operated as an open delta using only two transformers. Some farm and commercial customers may want 3-phase power at 240 volts and also single-phase power at 120/240 volts. By providing a center-tap to the secondary winding of one of the delta transformers both of these requirements can be provided with the same system as a 4-wire delta 240/120 volt, 3-phase system.

A copy of the latest edition of the *National Electrical Code* can be obtained from the National Fire Protection Association, One Batterymarch Park, Quincy, MA.